

Y

•

•

•

•

§ 2 1

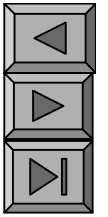
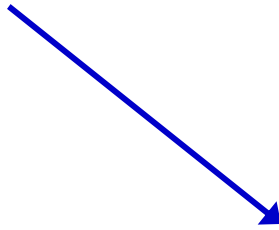

§ 2 2

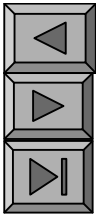

- (equivalence)

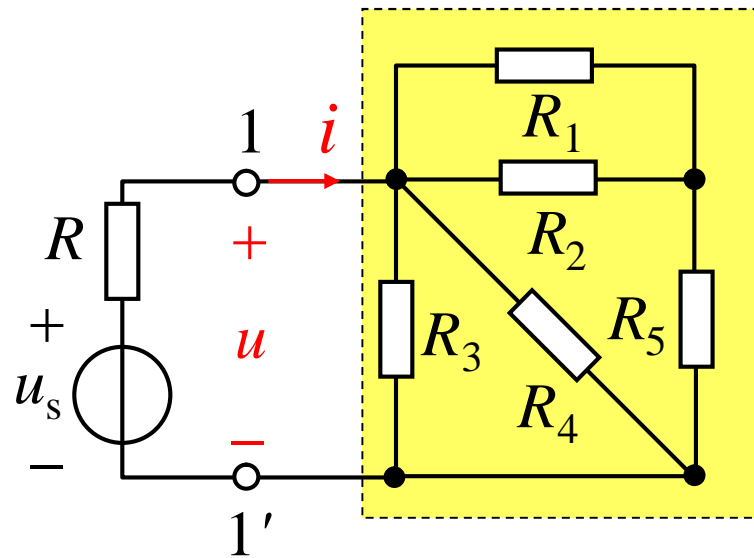

1-1'

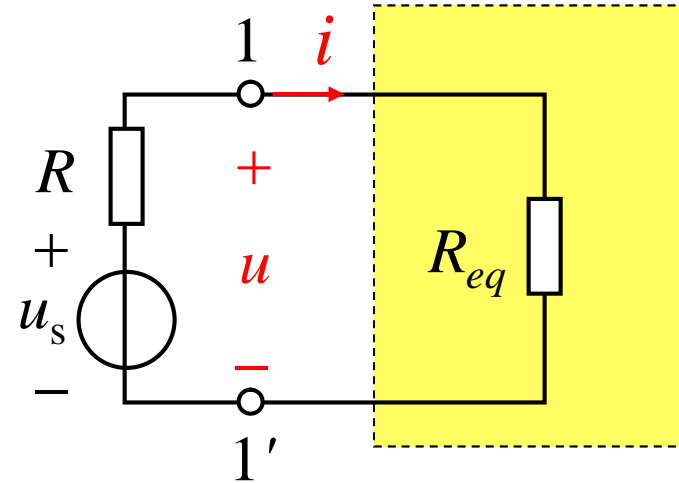

R_{eq}

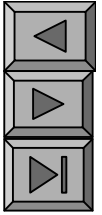

i u R_{eq}

1-1'

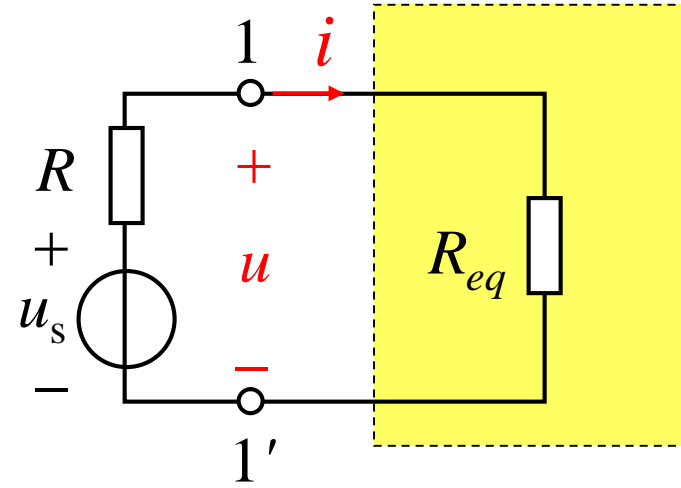
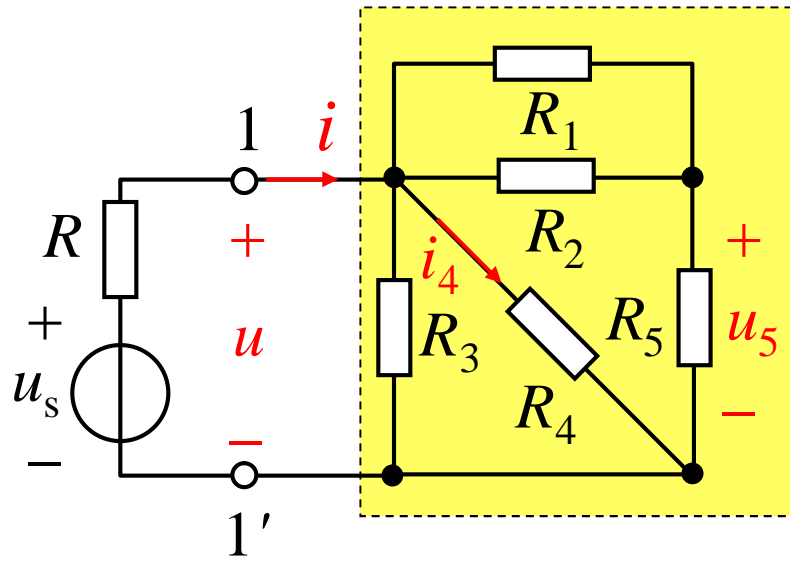

i_4 u_5

i u

§ 2 3

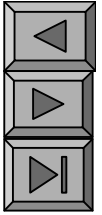

1.

KVL

$$\begin{aligned} u &= R_1 i + R_2 i + \dots + R_n i \\ &= (R_1 + R_2 + \dots + R_n) i \end{aligned}$$

$$u = R_{eq} i \quad (1)$$

$$R_{eq} \stackrel{\text{def}}{=} \sum_{k=1}^n R_k$$

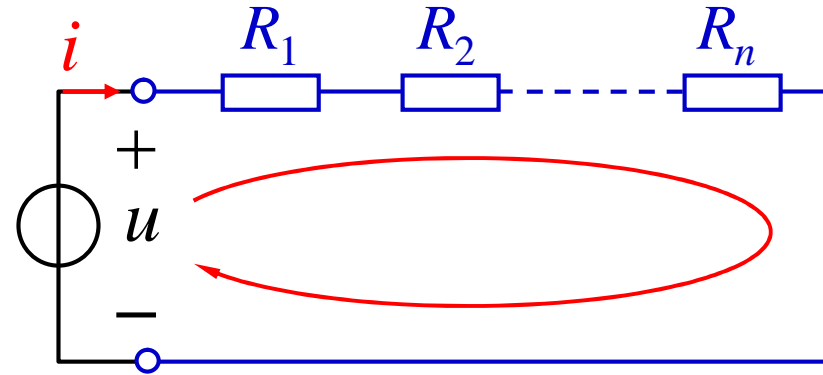

R_{eq}

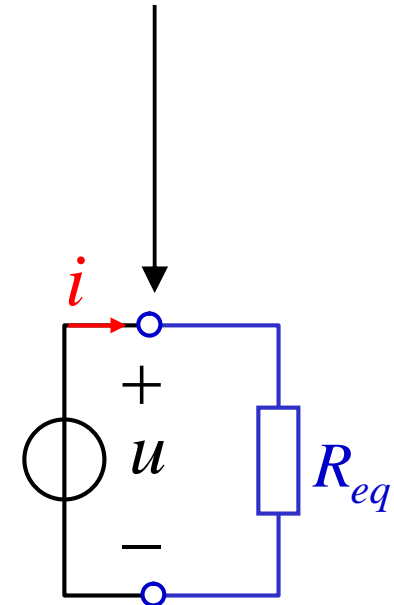

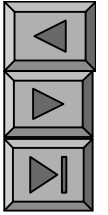

(2)

$$u_k =$$

$$+ u_1 - + u_2 - + u_n -$$

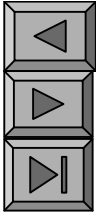

1.

2.



3.

4.

(1)

(2)

(3)

VCR

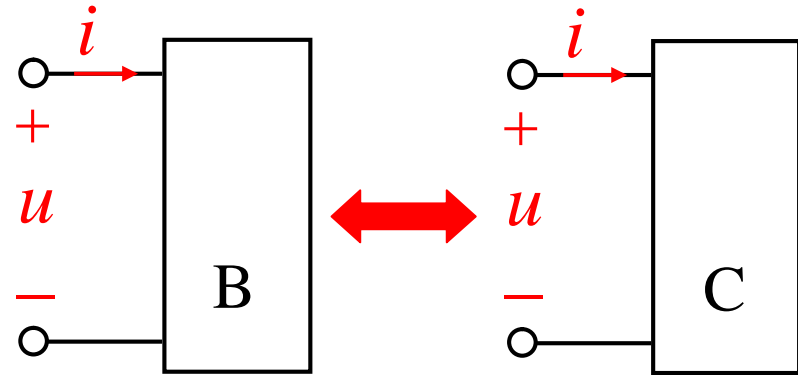

2.

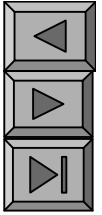
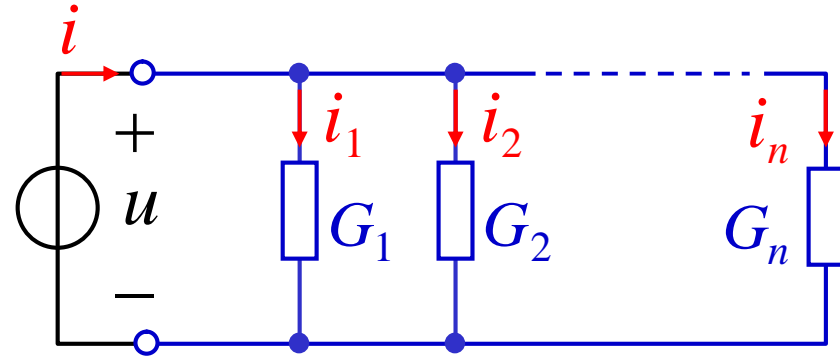

KCL

$$\begin{aligned} i &= i_1 + i_2 + \dots + i_n \\ &= G_1 u + G_2 u + \dots + G_n u \\ &= (G_1 + G_2 + \dots + G_n) u \end{aligned}$$

$$i = G_{eq} u$$

$$G_{eq} \stackrel{\text{def}}{=} \sum_{k=1}^n G_k$$

$$R_{eq} = \frac{1}{G_{eq}} = \frac{1}{\sum_{k=1}^n G_k}$$

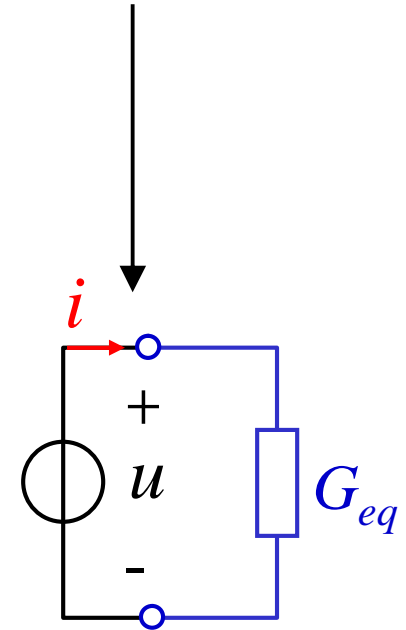

$$\frac{1}{R_{eq}} = \sum_{k=1}^n \frac{1}{R_k}$$

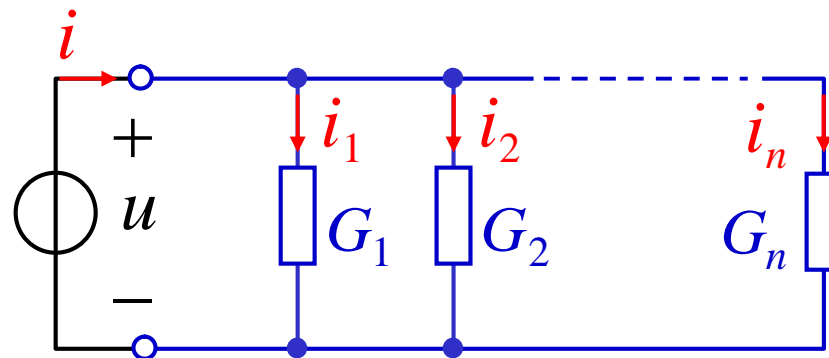

$$i_k = G_k u = G_k \frac{i}{G_{eq}}$$

$$i_k = \frac{G_k}{G_{eq}} i \quad \longrightarrow$$

$k = 1 \quad 2 \quad \dots \quad n$

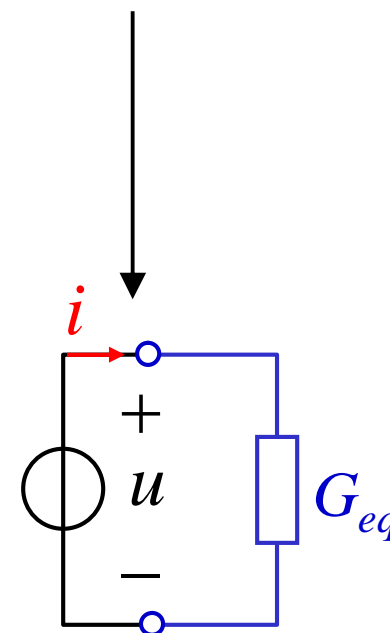

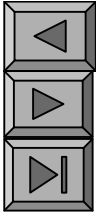

$$i_1 = \frac{\frac{1}{R_1}}{\frac{1}{R_1} + \frac{1}{R_2}} i = \frac{\frac{1}{\cancel{R_1}}}{\cancel{R_1} + R_2} i$$

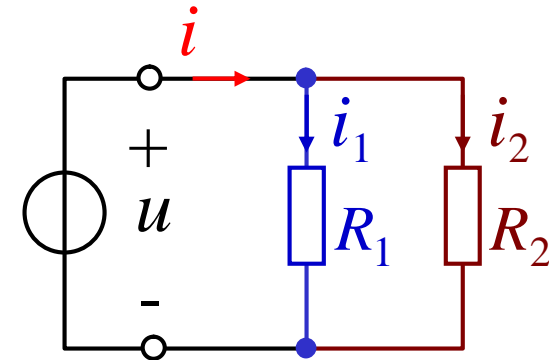

$$i_k = \frac{G_k}{G_{eq}} i$$

$$i_1 = \frac{R_2}{R_1 + R_2} i$$

$$i_2 = \frac{R_1}{R_1 + R_2} i$$

3.

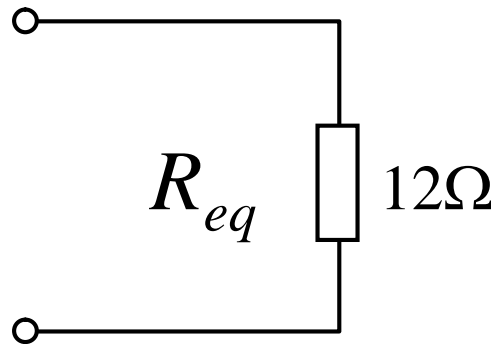
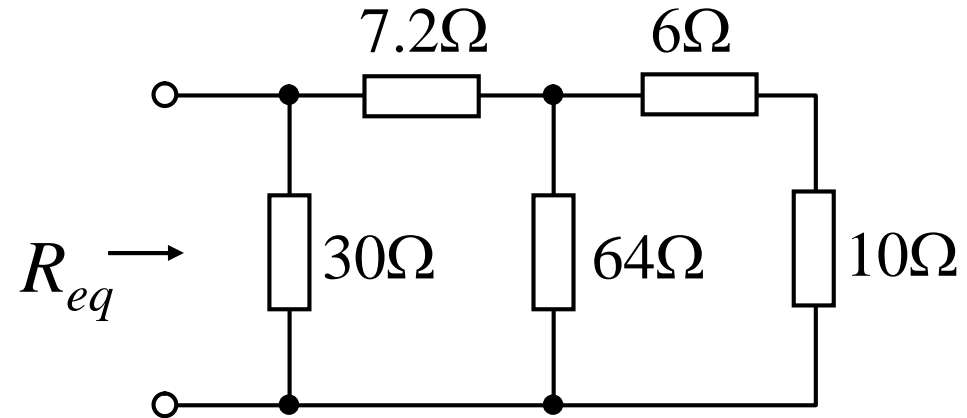
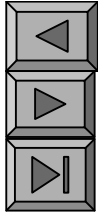

$$\frac{64 \times 16}{64 + 16} = 12.8\Omega$$

$$R_{eq} = \frac{30 \times 20}{30 + 20} = 12\Omega$$

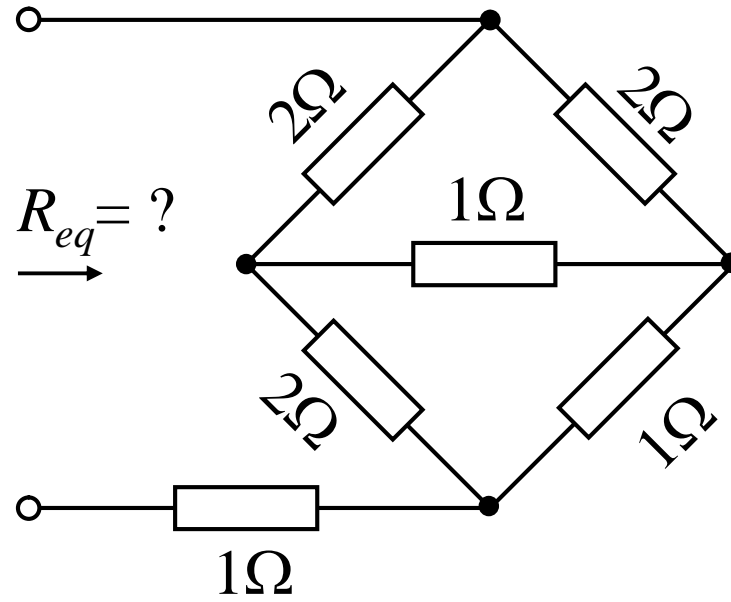
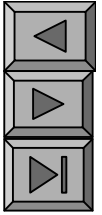

§ 2 4

Y

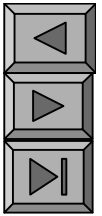

1. ()

T

2. ()

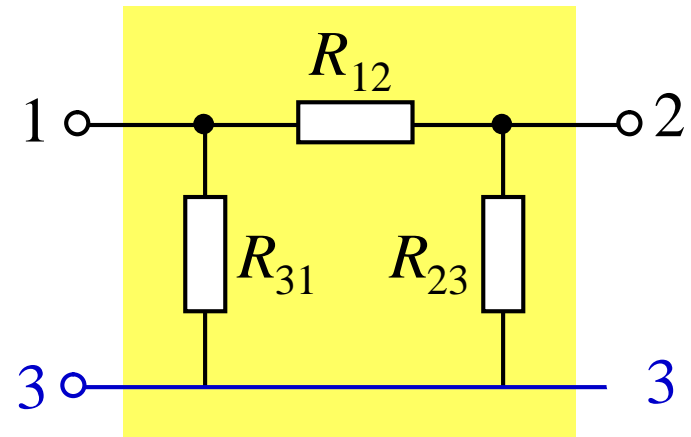
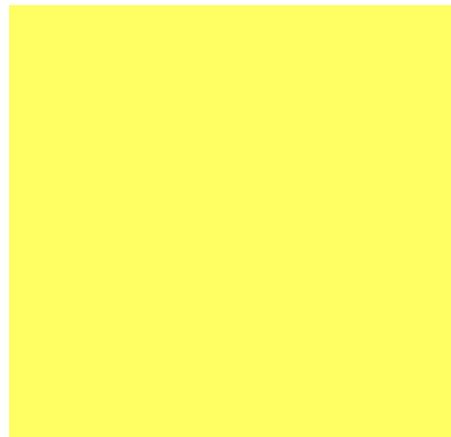
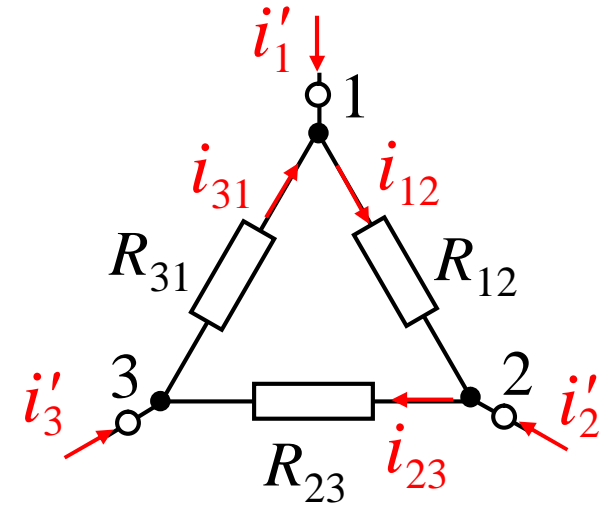
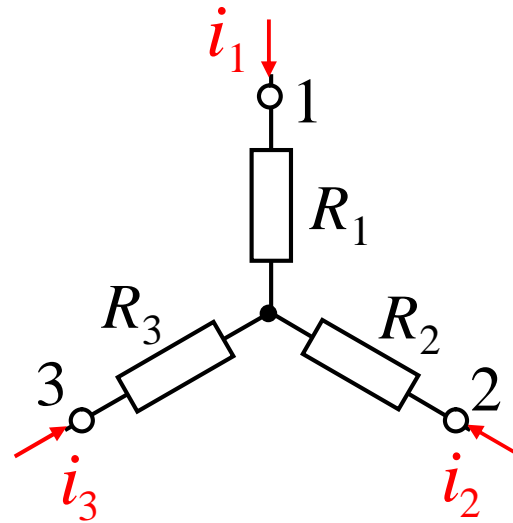

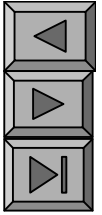

Y

$$i'_1 = \frac{u_{12}}{R_{12}} - \frac{u_{31}}{R_{31}}$$

$$i'_2 = \frac{u_{23}}{R_{23}} - \frac{u_{12}}{R_{12}}$$

$$i'_3 = \frac{u_{31}}{R_{31}} - \frac{u_{23}}{R_{23}}$$

KCL

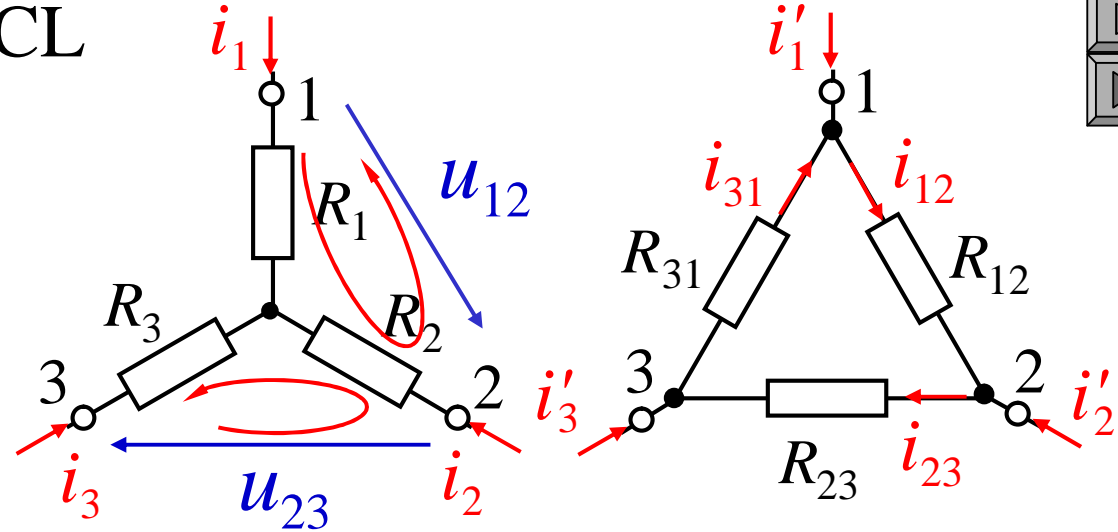

Y KCL KVL

$$\begin{cases} i_1 + i_2 + i_3 = 0 \\ R_1 i_1 - R_2 i_2 = u_{12} \\ R_2 i_2 - R_3 i_3 = u_{23} \end{cases}$$

$$i_1 = \frac{R_3 u_{12} - R_2 u_{31}}{R_1 R_2 + R_2 R_3 + R_3 R_1}$$

$$i_2 = \frac{R_1 u_{23} - R_3 u_{12}}{R_1 R_2 + R_2 R_3 + R_3 R_1}$$

$$i_3 = \frac{R_2 u_{31} - R_1 u_{23}}{R_1 R_2 + R_2 R_3 + R_3 R_1}$$

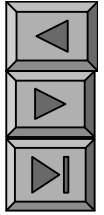

Y

$$\left. \begin{aligned} i'_1 &= \frac{u_{12}}{R_{12}} - \frac{u_{31}}{R_{31}} \\ i'_2 &= \frac{u_{23}}{R_{23}} - \frac{u_{12}}{R_{12}} \\ i'_3 &= \frac{u_{31}}{R_{31}} - \frac{u_{23}}{R_{23}} \end{aligned} \right\}$$

$$i_1 = \frac{R_3 u_{12} - R_2 u_{31}}{R_1 R_2 + R_2 R_3 + R_3 R_1}$$

$$i_2 = \frac{\quad}{R_1 R_2 + R_2 R_3}$$

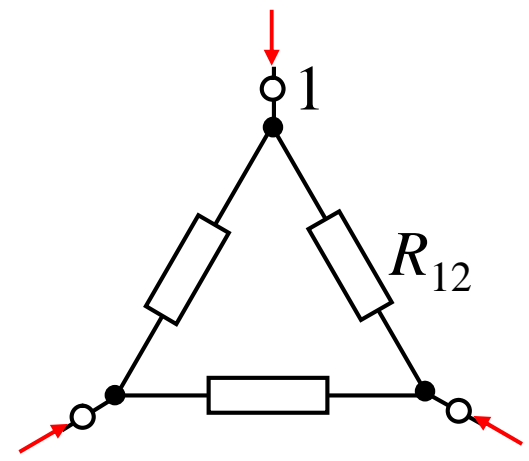
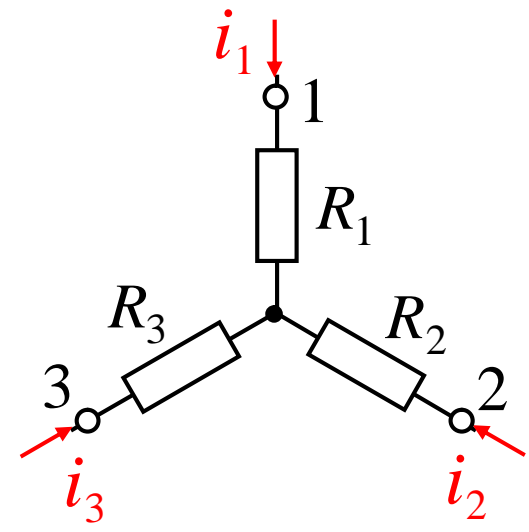
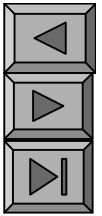

2

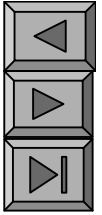

$$\begin{aligned} & \mathbf{Y} \\ & \boxed{R_1 R_2 + R_2 R_3 + R_3 R_1} = \underline{R_{12} R_3} = R_{23} R_1 = \underline{R_{31} R_2} \\ \left. \begin{aligned} R_{12} &= \frac{R_1 R_2 + R_2 R_3 + R_3 R_1}{R_3} \\ + \\ R_{23} &= \frac{R_1 R_2 + R_2 R_3 + R_3 R_1}{R_1} \\ + \\ R_{31} &= \frac{R_1 R_2 + R_2 R_3 + R_3 R_1}{R_2} \end{aligned} \right\} \\ & \downarrow \\ & R_{12} + R_{23} + R_{31} = \frac{R_{31}}{R_1} \quad R_{12} \\ & \quad R_1 \quad R_3 \quad R_1 = \frac{R_{12} R_{31}}{R_{12} + R_{23} + R_{31}} \end{aligned}$$

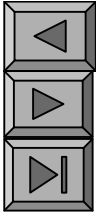

$R_2 \quad R_3$

$$R_1 = \frac{R_{12}R_{31}}{R_{12} + R_{23} + R_{31}}$$

$$R_2 = \frac{R_{23}R_{12}}{R_{12} + R_{23} + R_{31}}$$

$$R_3 = \frac{R_{31}R_{23}}{R_{12} + R_{23} + R_{31}}$$

$$R_Y = \frac{R}{R}$$

Y — ()

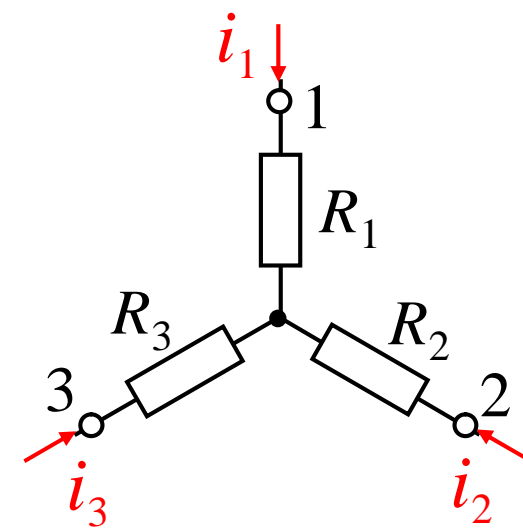
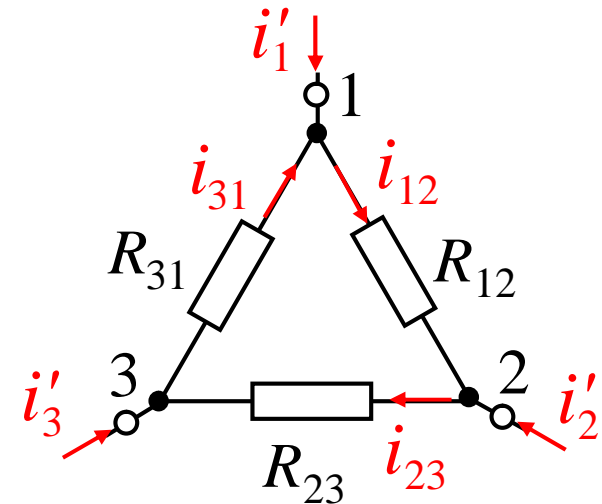

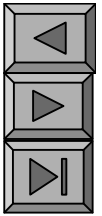

$$R = \frac{Y R}{Y}$$

$$R_1 R_2 + R_2 R_3 + R_3 R_1$$

$$R_{12} \text{ --- } R_3$$

$$R_{23} \text{ --- } R_1$$

$$R_{31} \text{ --- } R_2$$

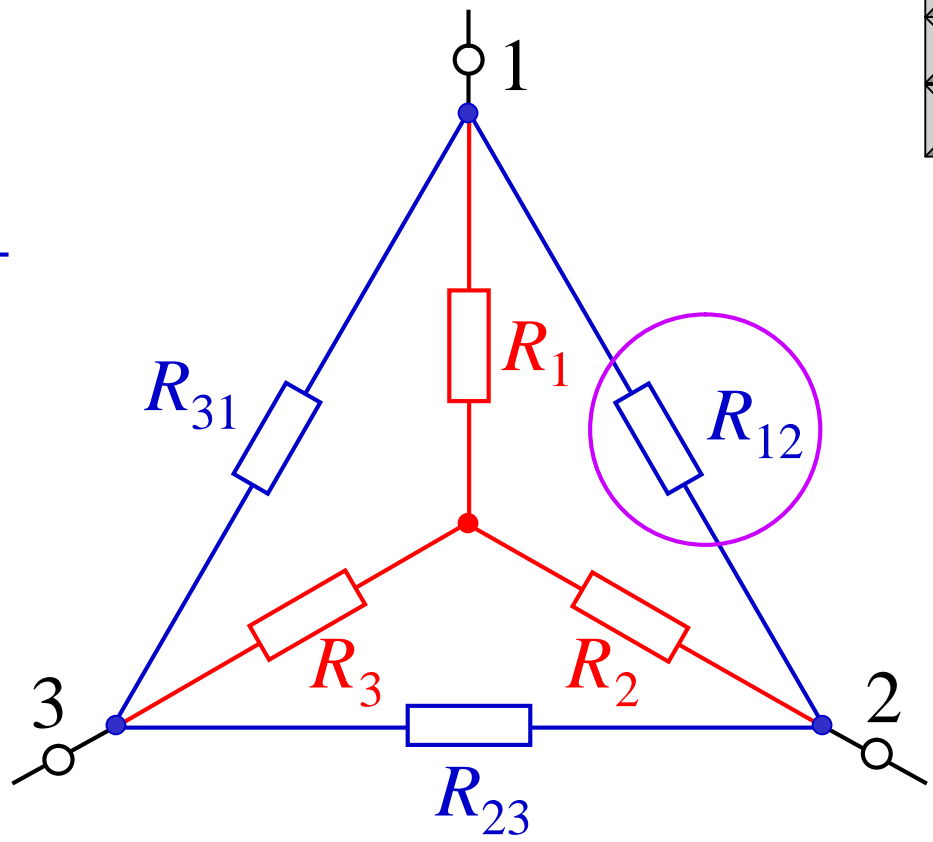

$$R_Y = \frac{R}{R_{12} + R_{23} + R_{31}}$$

$$R_1 \text{ --- } R_{12} R_{31}$$

$$R_2 \text{ --- } R_{23} R_{12}$$

$$R_3 \text{ --- } R_{31} R_{23}$$

P39 2-2

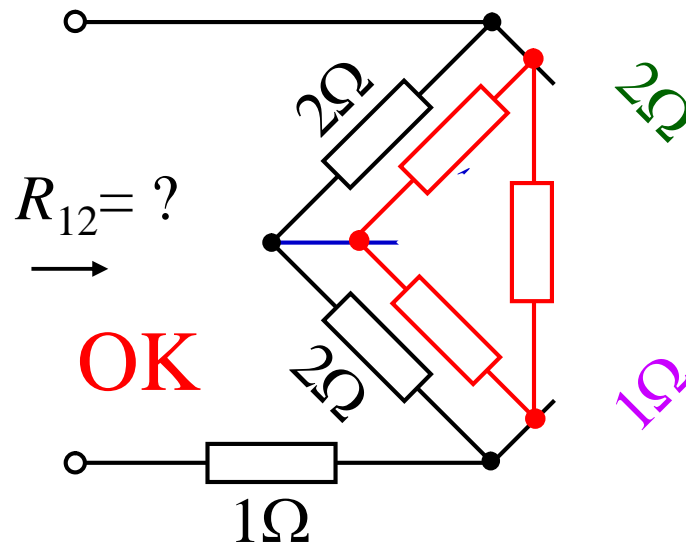
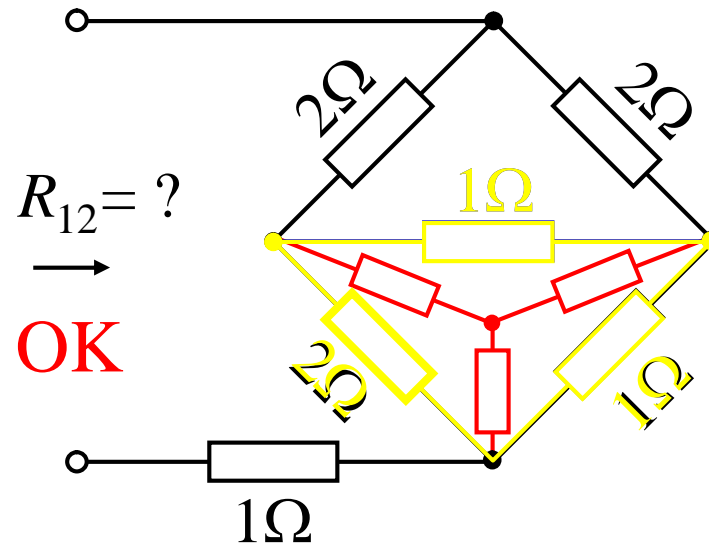
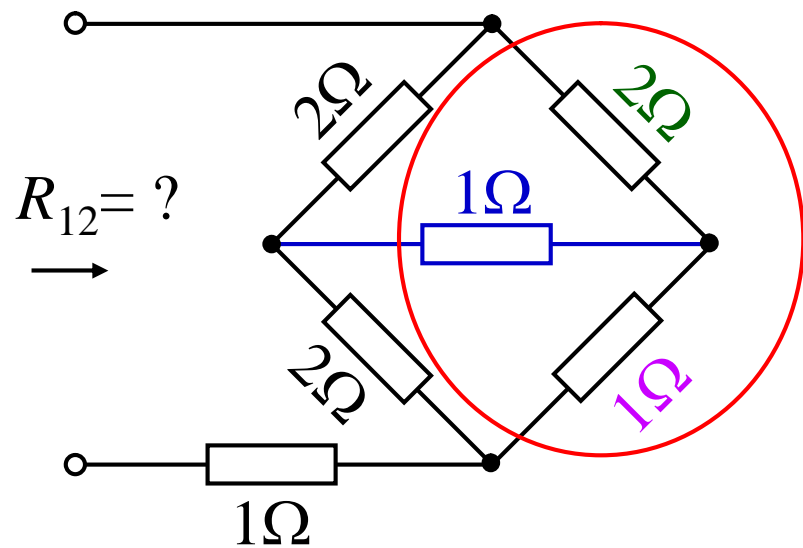
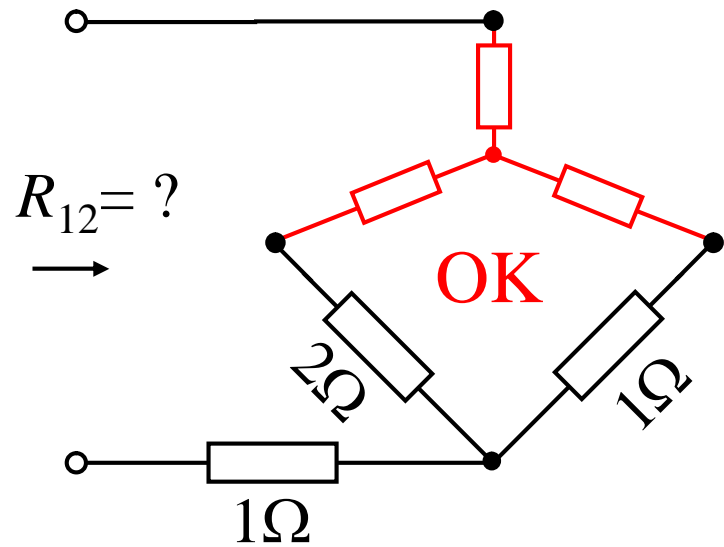

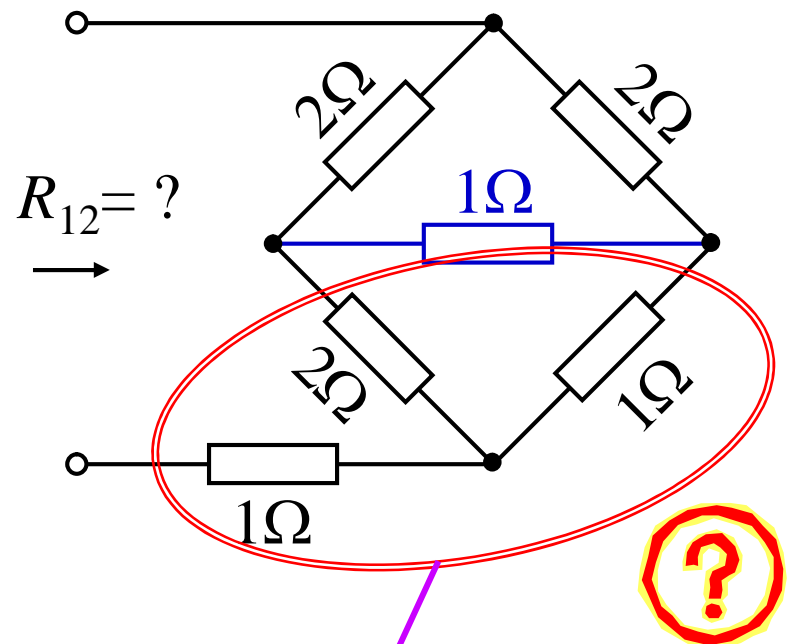
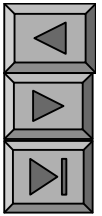

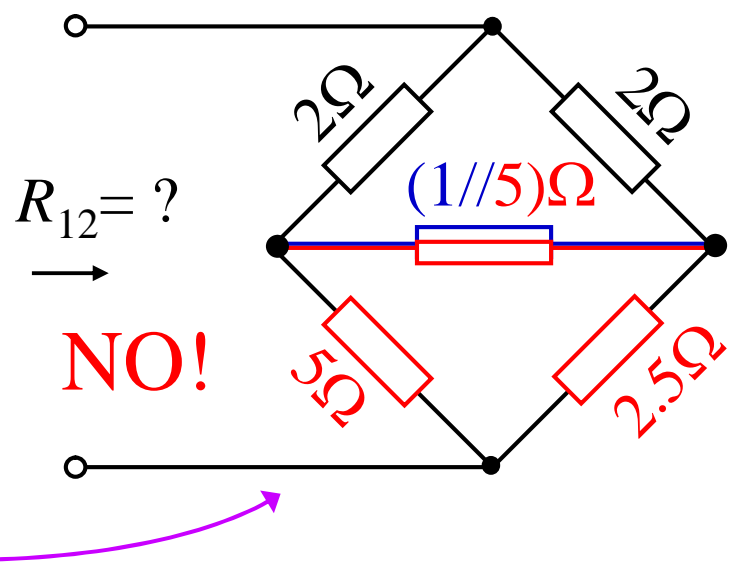
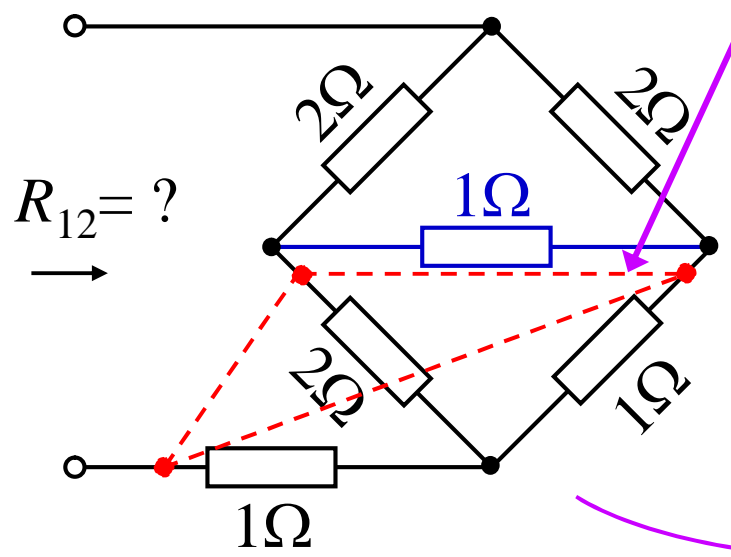

2010 

2. n

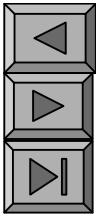
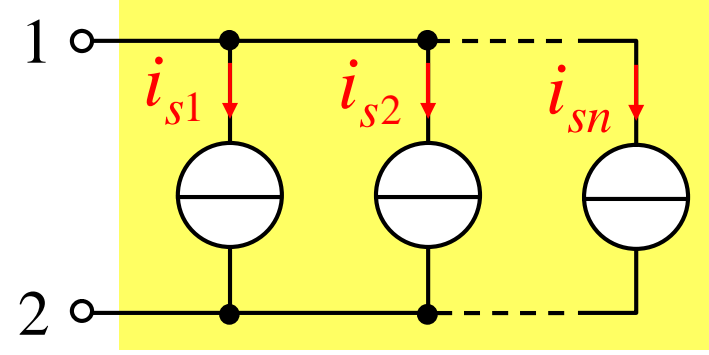
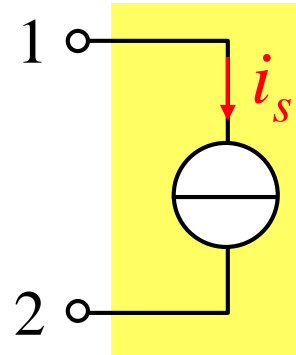

$$i_s = \sum_{k=1}^n i_{sk}$$

i_{sk} i_s
 i_{sk}

“+”

“-”

•



•



•

KVL KCL

§ 2 6

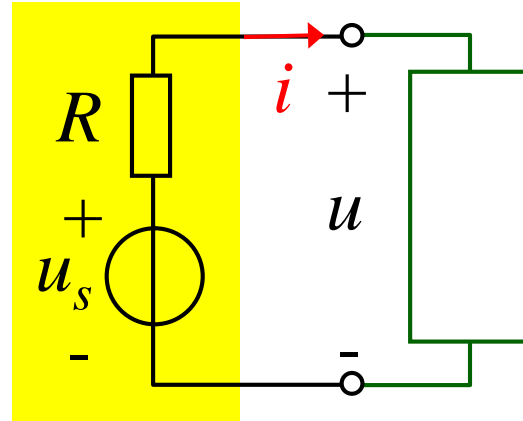
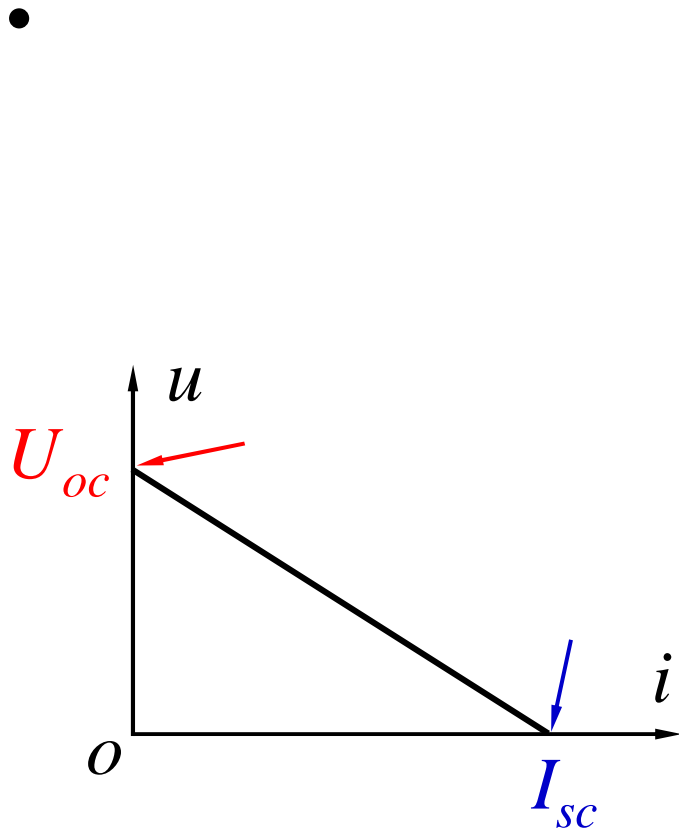
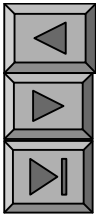

$$u = u_s - Ri$$

$$u_{oc} = u_s$$

$$i_{sc} = \frac{u_s}{R}$$

$$i_s = \frac{u_s}{R} \quad u_s = i_s R$$

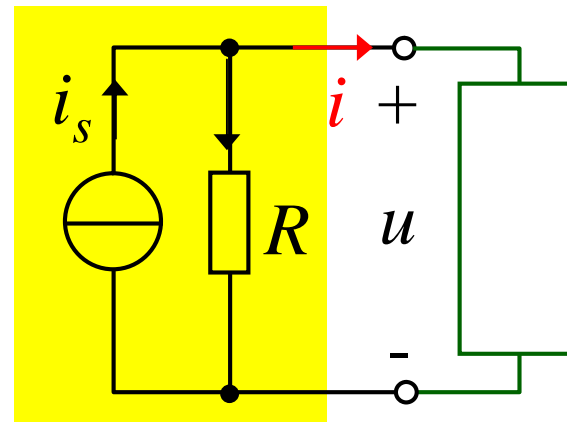

$$i = i_s - \frac{1}{R} u$$

$$u_{oc} = i_s R$$

$$i_{sc} = i_s$$

P43-44 2-3

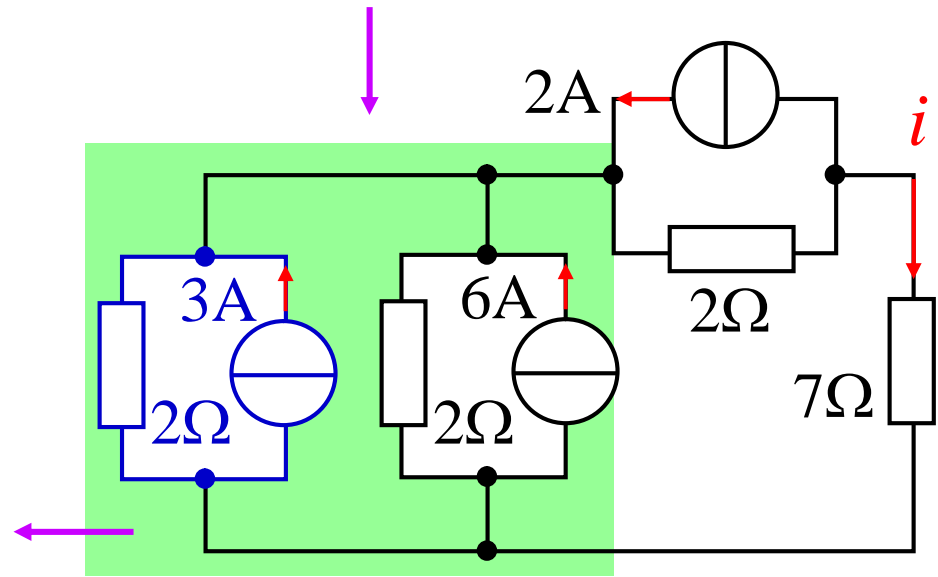
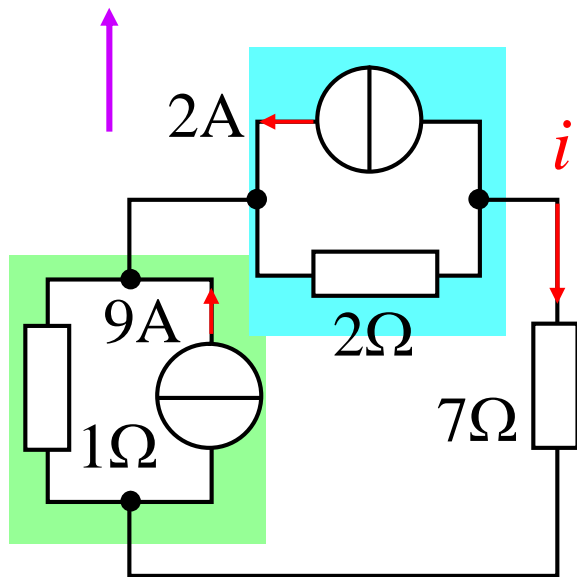
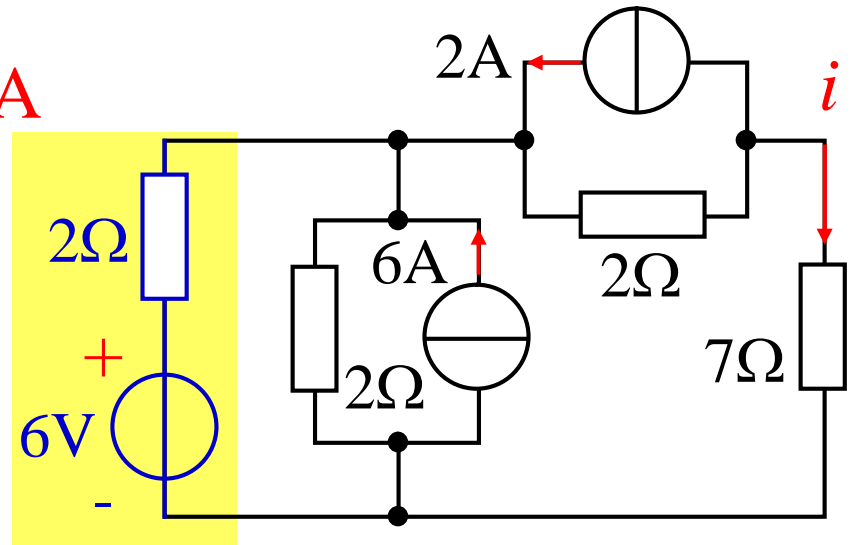
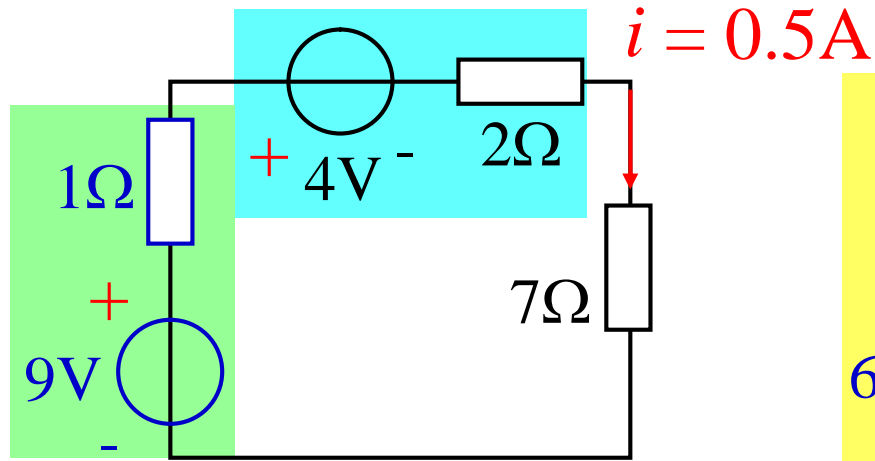
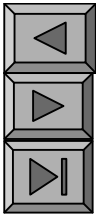

P45 2-4 $u_s=12\text{V}$ $R=2\Omega$ $g=2\text{ S}$ u_R .

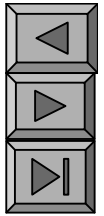
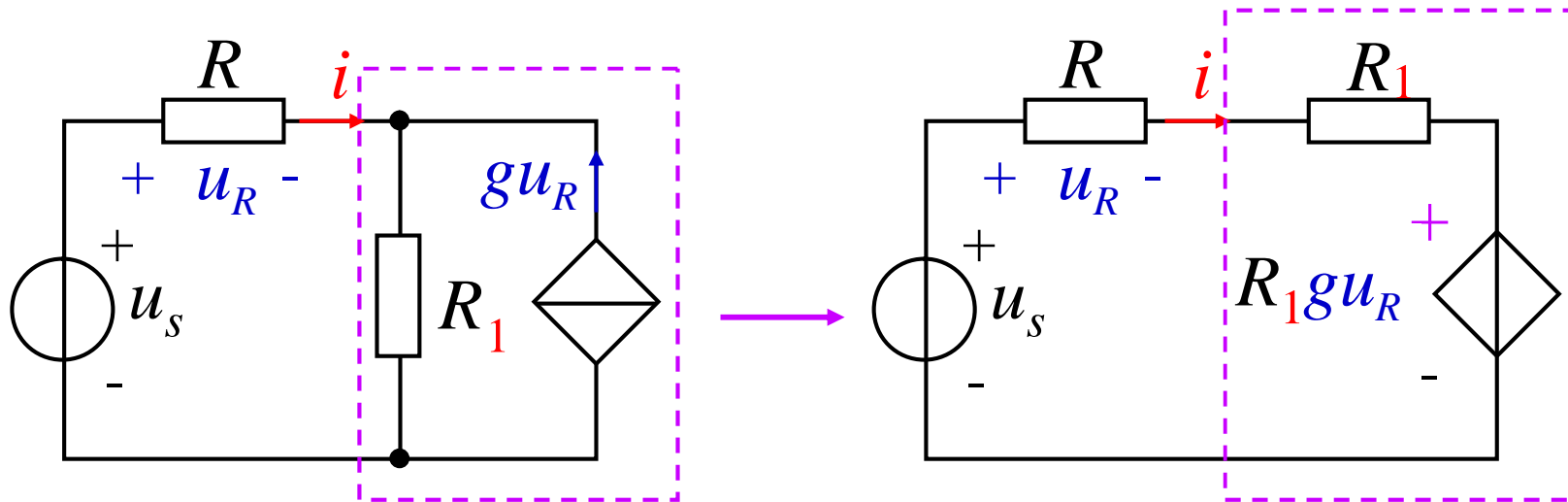

$$u_s = u_R + u_R + Rgu_R$$

$$u_R = \frac{u_s}{2 + Rg}$$

$$= \frac{12}{2 + 2 \times 2}$$

$$= 2\text{V}$$

$$i = \frac{u_R}{R}$$

$$u_s = u_R + \frac{u_R}{R} R_1 + R_1 g u_R$$

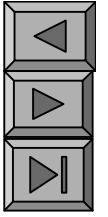

1.

4

(1)

(2)

(3)

(4)

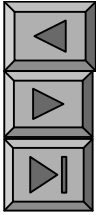

q

①

②

③

c

$$U_C = 0$$

$$I = 1\text{A}$$

$$U_a = 5\text{V}, \quad U_b = 2\text{V}, \quad U_d = -1\text{V}$$

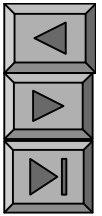
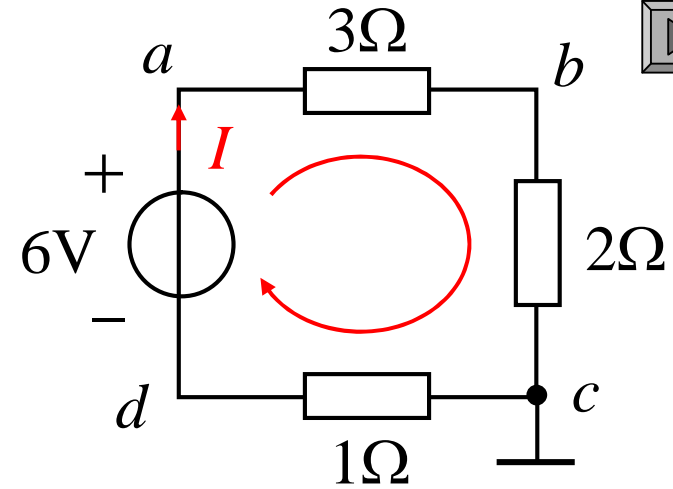

d

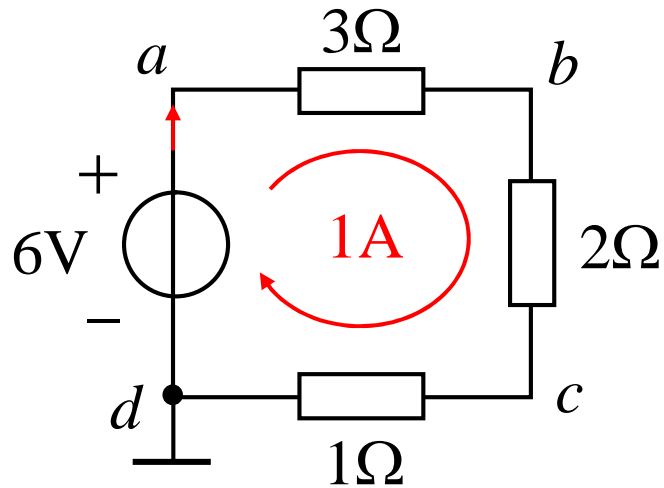

$$U_d = 0 \quad U_a = 6\text{V},$$

$$U_C = 1\text{V}, \quad U_b = 3\text{V},$$

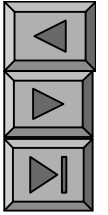

2. $-Y$
()

3.

n
 n

4.

VCR

§ 2 7

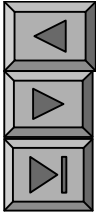

•



•

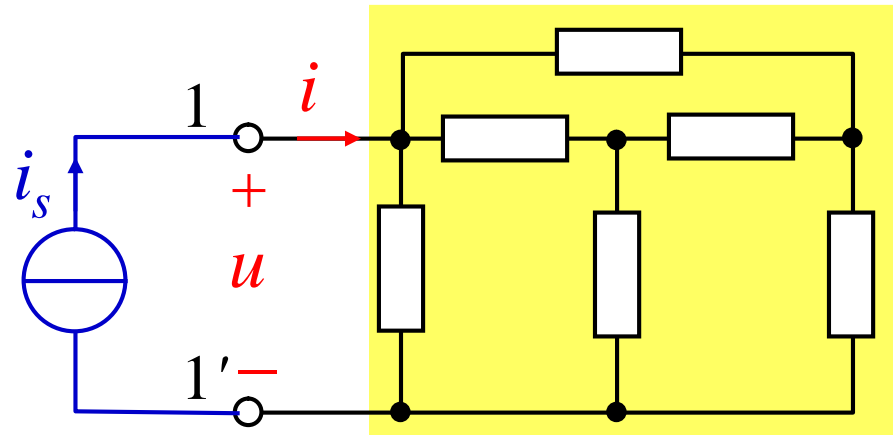
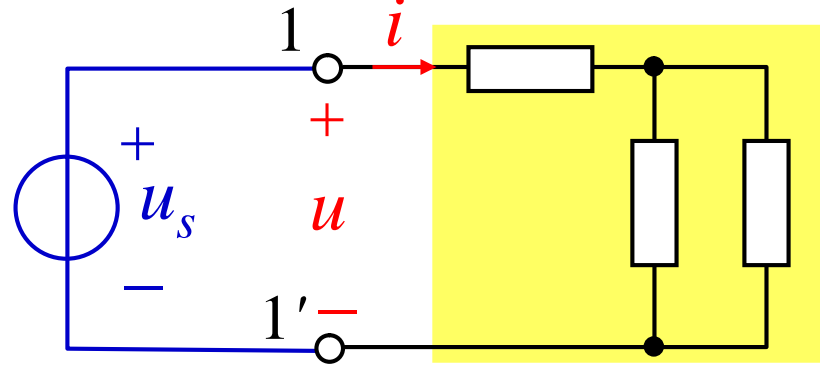
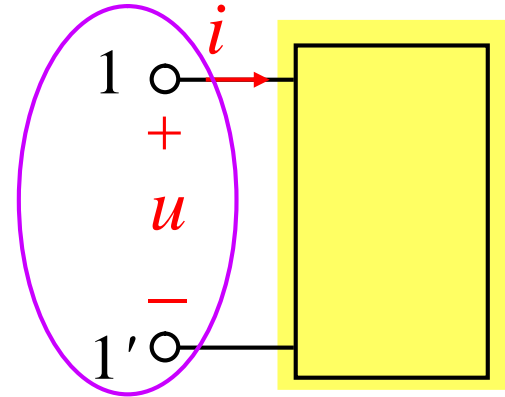

Y-

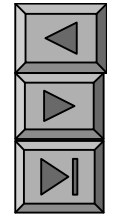
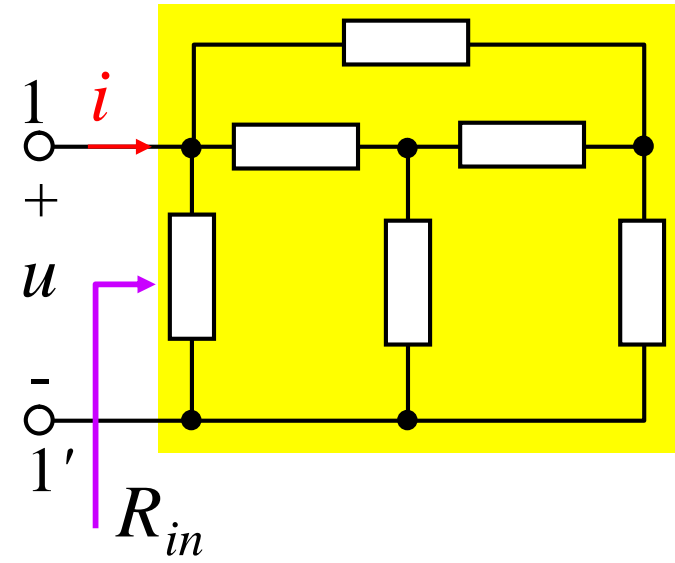

•

•

$$R_{in} \stackrel{\text{def}}{=} \frac{u}{i}$$

•

$$R_{in} = R_{eq}$$

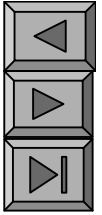

P46 2 5

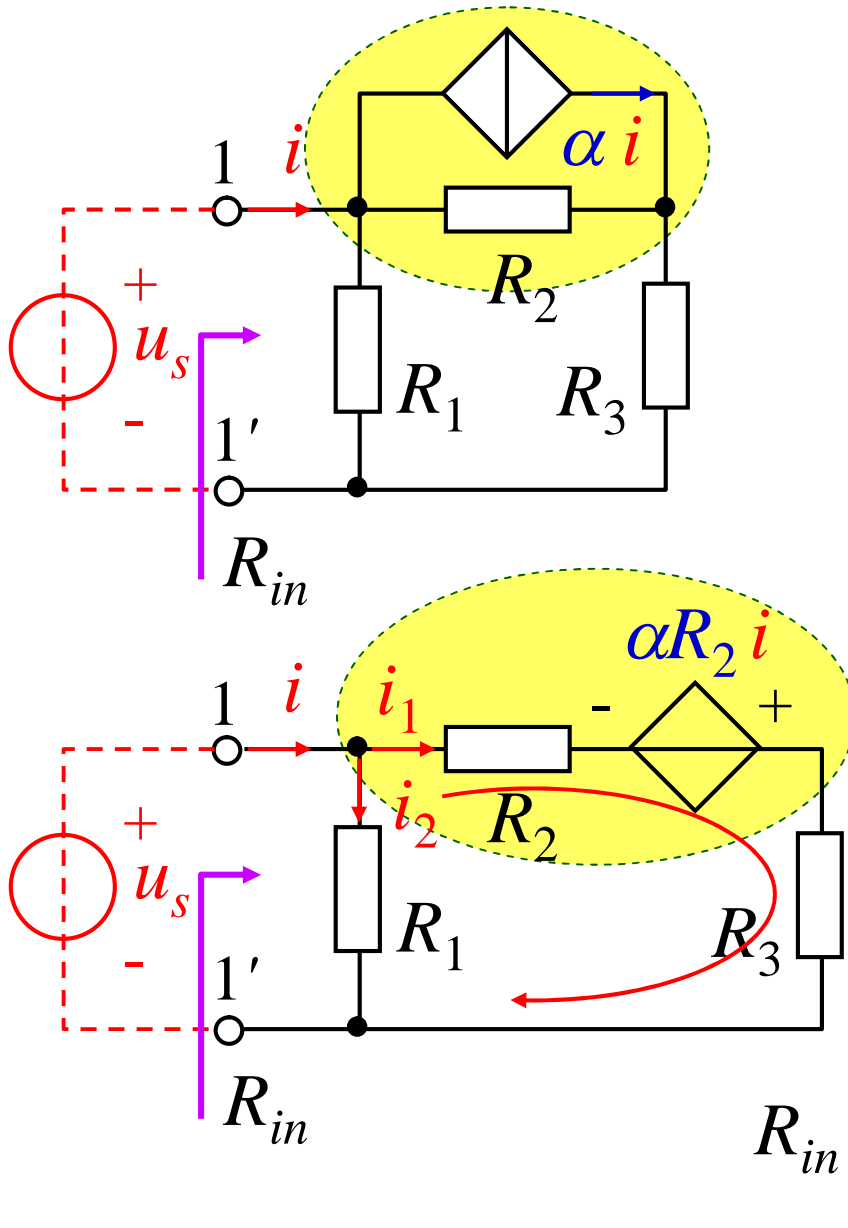

$$u_s = -\alpha R_2 i + (R_2 + R_3) i_1$$

$$i_2 = \frac{u_s}{R_1}$$

$$i_1 = i - i_2 = i - \frac{u_s}{R_1}$$

$$u_s = -\alpha R_2 i + (R_2 + R_3) \left(i - \frac{u_s}{R_1} \right)$$

$$u_s + \frac{(R_2 + R_3)}{R_1} u_s = -\alpha R_2 i + (R_2 + R_3) i$$

$$R_{in} = \frac{u_s}{i} = \frac{(R_1 R_3) + (1 - \alpha) R_1 R_2}{R_1 + R_2 + R_3}$$

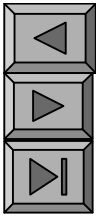

1.

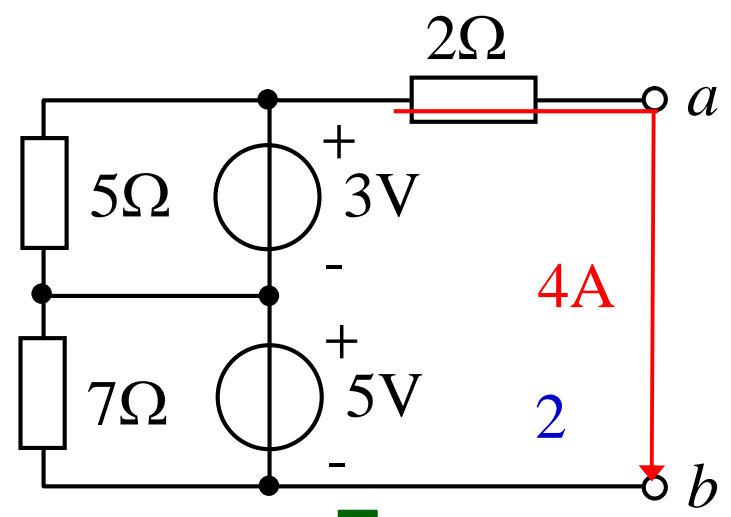
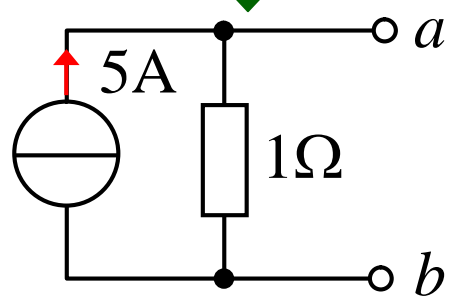
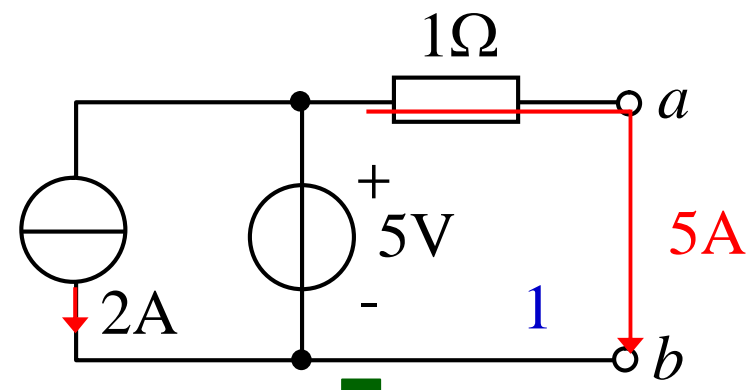

2Ω

2.

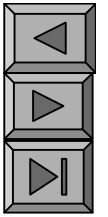
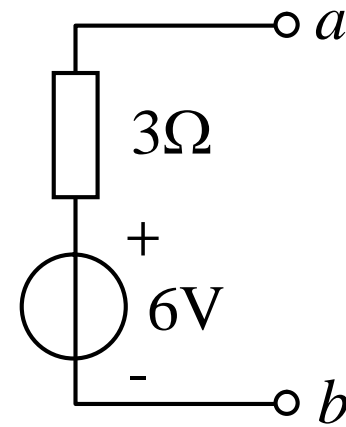
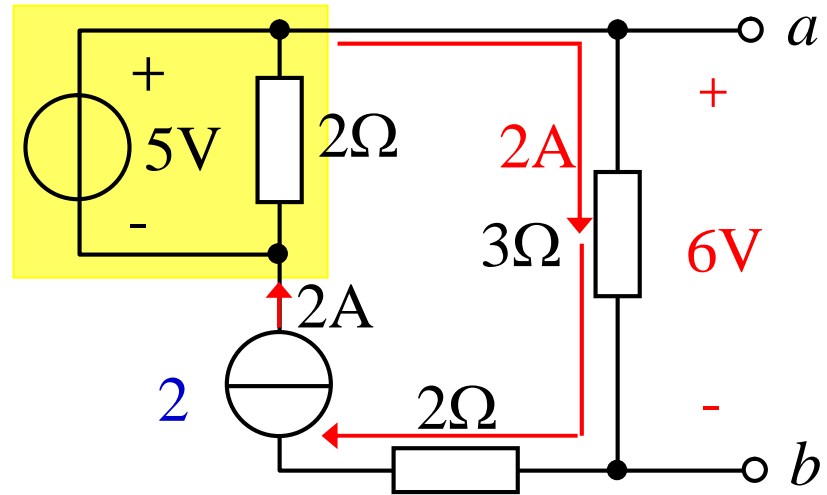
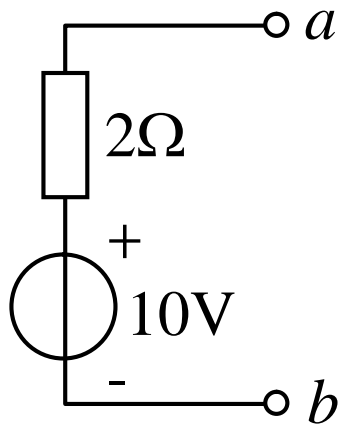
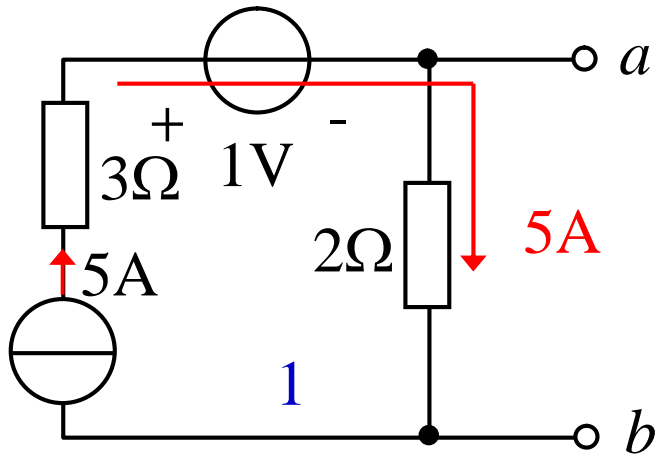

3.

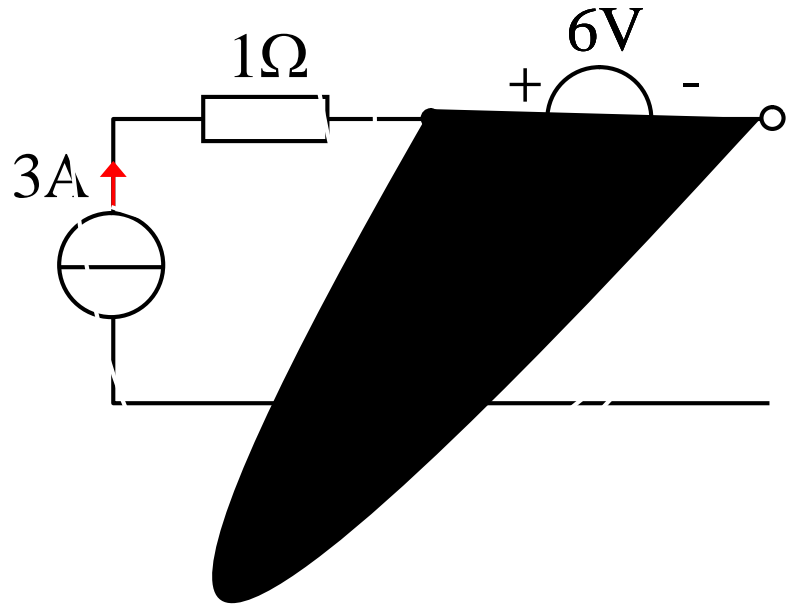

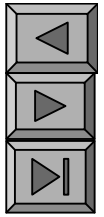

_____ 2-4 (e)

_____ 2-4 (g)

_____ 2 10

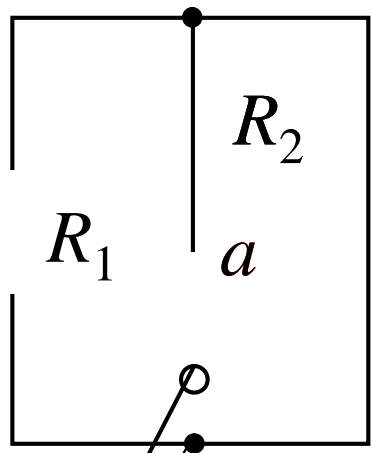
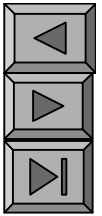

2 2 2 2 2 2 2 2

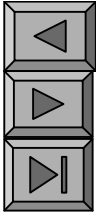

2-4 (e)

R_{ab} ($R=2\Omega$)

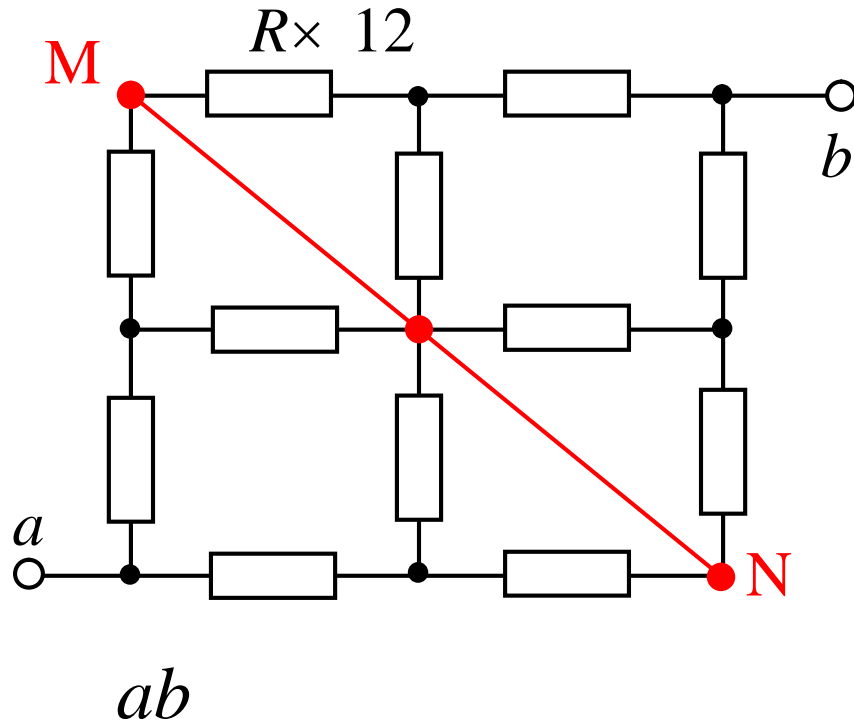

MN

$$\frac{R_{ab}}{2} = \left[\frac{R}{2} + R \right] // \left[\frac{R}{2} + R \right]$$

$$R_{ab} = \left[\frac{R}{2} + R \right] = \frac{3}{2} R$$

$$R = 2\Omega \quad R_{ab} = 3\Omega$$

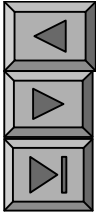

2-4 (g)

R_{ab} ($R=2\Omega$)

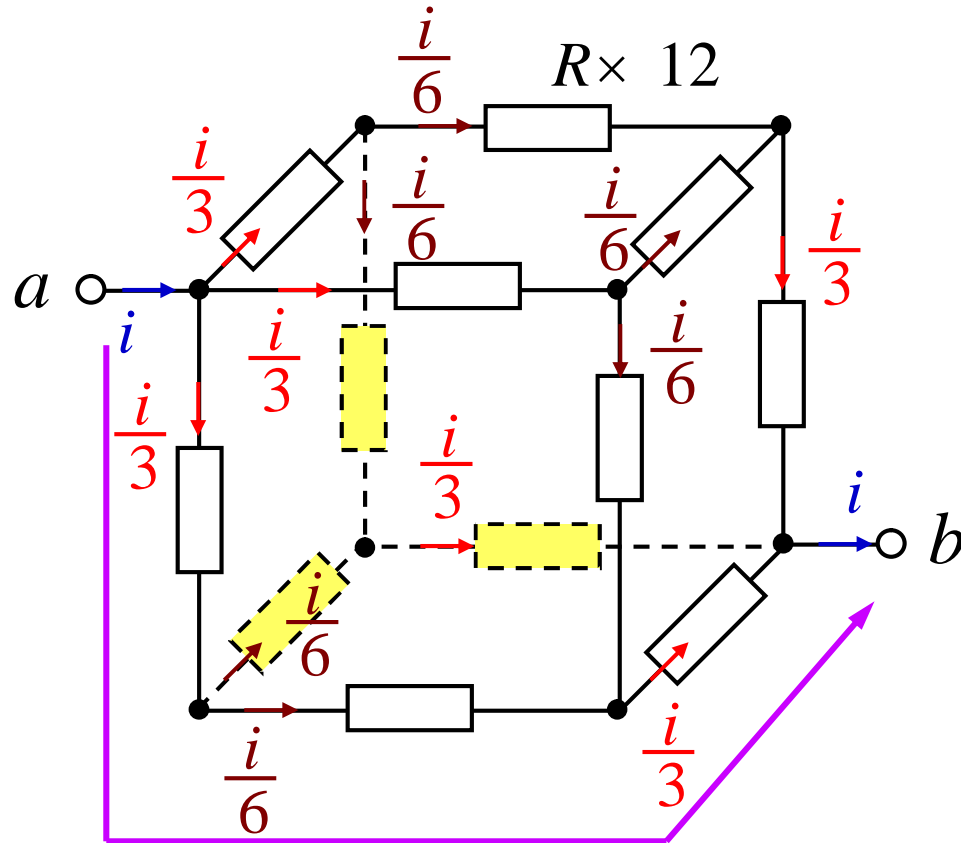

KVL

$$U_{ab} = \frac{i}{3} R + \frac{i}{6} R + \frac{i}{3} R$$

$$R_{ab} = \frac{U_{ab}}{i}$$

$$= \frac{1}{3} R + \frac{1}{6} R + \frac{1}{3} R$$

$$= \frac{5}{6} R$$

$$R=2\Omega$$

$$R_{ab} = 1.667\Omega$$

()

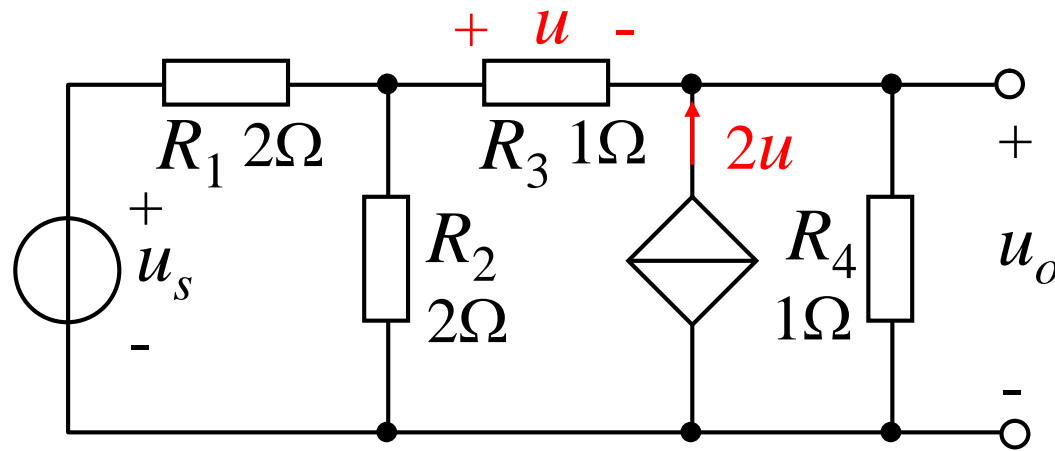
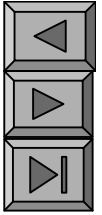

2 12

$$u = 1 \times i = i$$

$$3u + 2u = 0.5u_s$$

$$u = 0.1u_s$$

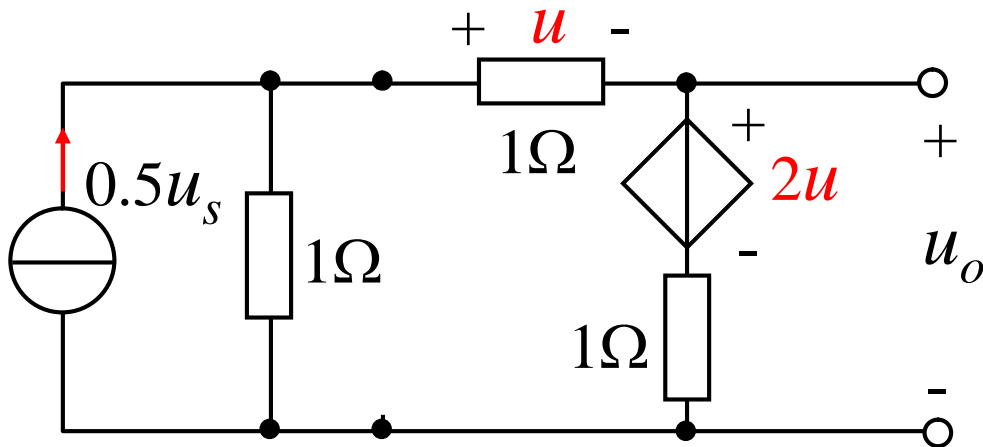

$$u_o = 2u + u = 3 \times 0.1u_s$$

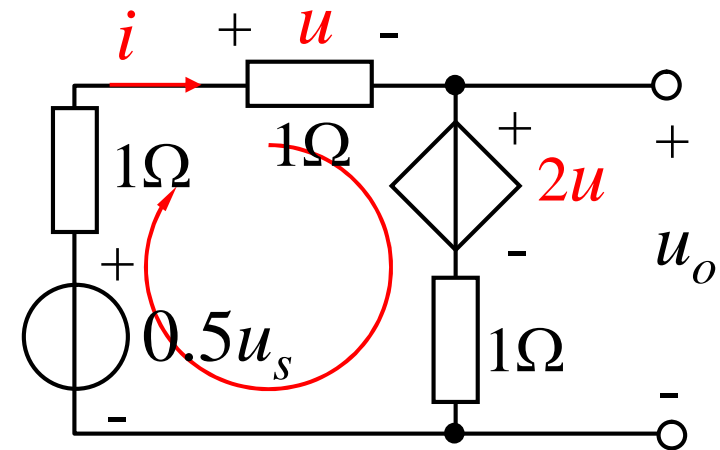

$$u_o / u_s = 0.3$$